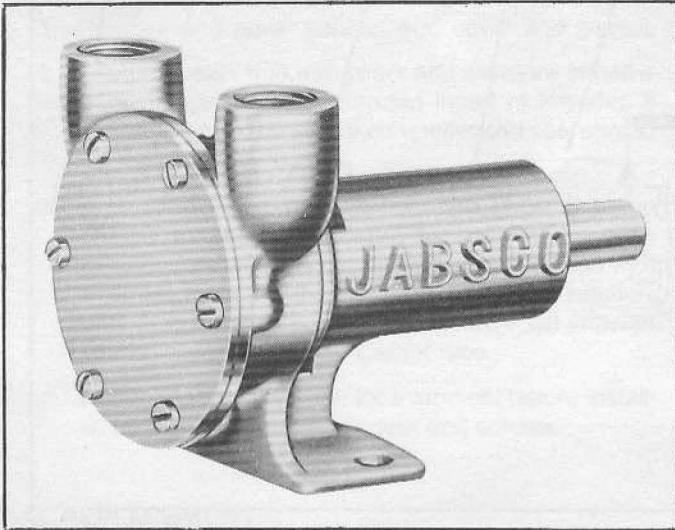

**JABSCO**[®]**Model 5320-0011**

SELF-PRIMING PUMP

FEATURES

Body:	Bronze Construction
Impeller:	Jabsco Neoprene Compound with Brass Extended Insert
Shaft:	Steel
Wear Plate:	Replaceable
Shaft Seal:	Lip Type
Bearings:	Sealed Fan Shaft Bearing
Ports:	3/8" NPT Vertical
Weight:	3 lbs (approximately) (1,36 kg)

Model 5320-0011

APPLICATIONS

INDUSTRIAL

Circulating and transferring liquids
Velocity-mixing
Pumping coolants on machine tools
Returning spilled liquids to process
Pumping waste water to sewer
Cellar, yards and sump drainage
Chemical manufacturers and pharmaceutical houses - to pump soap, liquors, ink, dyes, medicines, alcohol, various acids, tanning liquors, glycerine, lotions, brine, etc.

MARINE

Pumping bilges, washdowns
Circulating water in bait tanks
Utility dock side pump
Circulating engine raw water

OPERATING INSTRUCTIONS

- INSTALLATION** – Pump may be mounted in any position. The rotation of the pump shaft determines the location of the pump's intake and discharge ports. Refer to dimensional drawing. Before starting, turn the pump shaft in the direction of the operating rotation.
- DRIVE** – Belt or Direct with flexible coupling.
BELT DRIVE – Overtight belt load will reduce bearing life.
**WARNING**
EXPOSED PULLEYS AND BELTS CAN CAUSE INJURY. INSTALL SHIELD AROUND PULLEYS AND BELTS.
DIRECT DRIVE – Clearance should be left between drive shaft and pump shaft when installing coupling. Always mount and align pump and drive shaft before tightening the set screw.
NOTICE: If drive pulley or coupling must be pressed on shaft, remove end cover and support shaft from impeller end during press operation. Do not hammer a pulley or coupling on shaft. Failure to follow above instructions can damage the pump.
- SPEEDS** – 100 RPM to the maximum shown in the performance table. For longer pump life, operate at lowest possible speeds.
- SELF-PRIMING** – Primes at low or high speeds. For vertical dry suction lift of 10 feet (3,0 m), a minimum of 800 RPM is required. Pump will produce suction lifts up to 22 feet (6,7 m) when wetted. **BE SURE SUCTION LINES ARE AIRTIGHT OR PUMP WILL NOT SELF-PRIME.**
- NOTICE** – If pumping light fraction petroleum derivatives, solvents, thinners, highly concentrated or organic acids, consult Jabsco Chemical Resistance Table (which is available upon request from ITT Jabsco) for proper body materials and impeller compounds. If corrosive fluids are handled, pump life will be prolonged if pump is flushed with water after each use or after each work day.
- PRESSURES** – For continuous operation, pressure should not exceed 20 PSI (1,4 kg/sq cm).
- TEMPERATURES** – Impeller is specially compounded to operate between 45° - 180°F (7° - 82°C).
- FREEZING TEMPERATURES** – Drain unit by loosening end cover. The following anti-freeze compounds can be used without any adverse effect to the neoprene impeller: Atlas "Permaguard", DuPont "Zerex" and "Telar", Dow Chemical "Dowguard" and Olin Mathison "Pyro". Most methyl alcohol (methanol) based anti-freezes can be used. **DO NOT USE PETROLEUM BASED ANTI-FREEZE COMPOUNDS OR RUST INHIBITORS.**
- GASKET** – Use standard pump part. A thicker gasket will reduce priming ability. A thinner gasket will cause impeller to bind. Standard gasket is 0.010" thick.
- SPARE PARTS** – A Jabsco Service Kit 90044-0001 should be kept on hand to service all but the most badly worn pumps.

EXPLODED VIEW

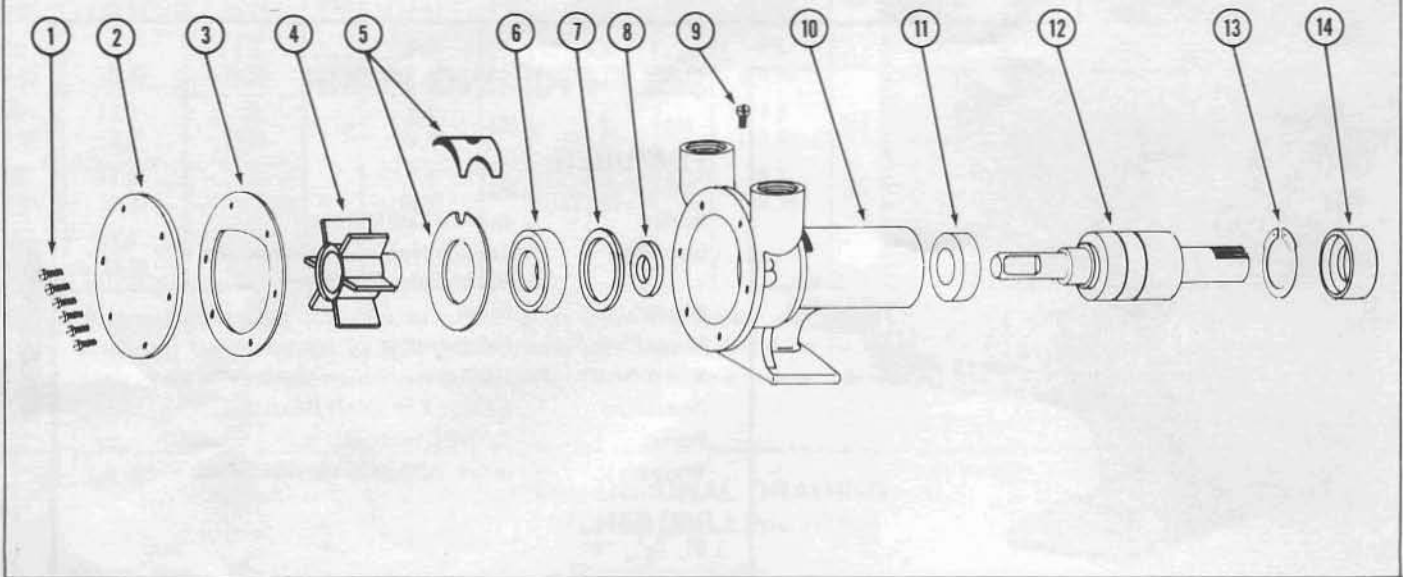

PARTS LIST

Key	Description	Part Number	Qty.
1	Screw, End Cover	91002-0020	6
2	End Cover	11830-0000	1
3	*Gasket, End Cover	2995-0000	1
4	*Impeller with Brass Insert	5616-0001	1
5	Cam and Wearplate Assembly	7895-0001	1
6	*Seal, Shaft	92700-0420	1
7	*O-Ring	92000-0540	1
8	Slinger	879-0000	1
9	Screw, Cam	91002-0090	1
10	Body	4484-0000	1
11	Bearing Seal, Inner	93000-0070	1
12	Shaft and Bearing Assembly	6020-0000	1
13	Retaining Ring, Bearing to Body	91701-0040	1
14	Bearing Seal, Outer	92700-0310	1
Not Shown	Key, Pump Drive	9215-0010	1
	Service Kit	90044-0001	

*Parts Contained in Service Kit

SERVICE INSTRUCTIONS

● Disassembly Steps

IMPELLER REPLACEMENT

- 1. Remove end cover screws, end cover and gasket.
- 2. Grasp impeller hub with pliers and withdraw impeller from pump. Inspect extended insert of impeller. If deeply grooved by seal, the impeller and seal should be replaced.
- 3. Wipe shaft clean. Apply a light film of water pump grease to shaft and outer surfaces of impeller-extended insert. Direct impeller insert onto shaft with a turning motion in the intended direction of rotation, until ding in insert contacts shaft flat. Push impeller into bore until flush with gasket face.
- 4. Immerse gasket in water for a moment before installation. Install gasket, end cover and screws.

SEAL REPLACEMENT

- 5. Remove end cover, gasket and impeller.
- 6. Loosen cam screw several turns. Tap screw firmly to break bond between cam and body. Remove and clean both cam and screw.
- 7. Use hooked wire to remove wearplate from impeller bore. Inspect wearplate. Replace if worn.
- 8. Use hooked wire to dislodge shaft seal from body. (If seal will not dislodge by pulling on it at several places, it may be necessary to press out shaft and seal.) Remove O-ring from groove in seal bore. Wipe seal bore clean.
- 9. Insert O-ring in groove of seal bore.
- 10. Apply a liberal amount of water pump grease to lip of seal. Dip seal in water then push into seal bore with lip facing impeller bore.
- 11. Position wearplate in back of impeller bore, with nipple towards impeller bore.
- 12. Coat top surface of cam and cam screw threads with sealant. Position cam in body with nipple of wearplate and slot of cam aligned. Install and tighten cam screw.
- 13. Install impeller, gasket and end cover as in Steps 3 and 4.

■ Assembly Steps

BEARING AND SHAFT ASSEMBLY REPLACEMENT

- 14. Remove end cover, gasket, impeller, cam, wearplate and seal as in Steps 1, 2, 6, 7 and 8.
- 15. Use hooked wire to remove slinger from impeller end of shaft.
- 16. Carefully insert screwdriver between outside diameter of outer bearing seal and pump bearing bore, then pry seal from bore.
- 17. Remove bearing-to-body retaining ring.
- 18. From impeller end of pump, press shaft out of pump.
- 19. Remove inner bearing seal by pressing away from impeller bore. Clean residue from bearing bore.
- 20. Apply liberal amount of grease to lip of inner bearing seal. Dip seal in water and press it into bearing pore with lips facing impeller bore.
- 21. Lubricate shaft next to bearing with water pump grease. Press shaft and bearing assembly into bearing bore. **DO NOT PRESS AGAINST SHAFT.** Press against outer race of bearing. Press assembly into bore from bearing bore end of body.
- 22. Install retaining ring in groove next to bearing. Flat side of ring should be next to bearing race.
- 23. Lubricate shaft exposed in bearing bore with grease. Lubricate lip of outer bearing seal. Press seal into bearing bore with lip facing away from bearing.
- 24. Slide slinger onto shaft through impeller and seal bores. Position slinger in drain slot area.
- 25. Install seal, wearplate, cam, impeller, gasket and end cover as in Steps 9, 10, 11, 12, 3 and 4.

CAUTION: PUMPS WHICH HAVE HANDLED CORROSIVE, CAUSTIC OR TOXIC FLUIDS SHOULD BE DRAINED AND COMPLETELY FLUSHED PRIOR TO SERVICING. FAILURE TO DO SO MAY CAUSE INJURY.

HEAD CAPACITY TABLE

TOTAL HEAD		500 RPM		1160 RPM		1750 RPM		2100 RPM		2450 RPM		3000 RPM		3600 RPM	
Head in Feet (Meters)	Lbs. per Sq. Inch (kg/sq cm)	GPM (Liter/Min)	HP	GPM (Liter/Min)	HP	GPM (Liter/Min)	HP	GPM (Liter/Min)	HP	GPM (Liter/Min)	HP	GPM (Liter/Min)	HP	GPM (Liter/Min)	HP
10 (3,0)	4.3 (0,3)	1.5 (5,7)	1/12	4.0 (15,1)	1/6	6.0 (22,7)	1/4	7.3 (27,6)	1/4	8.4 (31,8)	1/3	10.3 (39,0)	1/3	11.9 (45,0)	1/3
20 (6,1)	8.7 (0,6)	1.2 (4,5)	1/12	3.3 (12,5)	1/6	5.2 (19,7)	1/4	6.5 (24,6)	1/4	7.5 (28,4)	1/3	9.4 (35,6)	1/3	10.8 (40,9)	1/3
30 (9,1)	13.0 (0,9)	.5 (1,9)	1/12	2.4 (9,1)	1/6	4.2 (15,9)	1/4	5.5 (20,8)	1/4	6.5 (24,6)	1/3	8.4 (31,8)	1/3	9.6 (36,3)	1/2
40 (12,2)	17.3 (1,2)			1.4 (5,3)	1/6	3.0 (11,4)	1/4	4.3 (16,3)	1/4	5.3 (20,1)	1/3	7.1 (26,9)	1/3	8.2 (31,0)	1/2
50 (15,2)	21.6 (1,5)											5.6 (21,2)	1/3	6.7 (25,4)	1/2

NOTE: Progressively longer life may be expected as operating speeds are reduced. Factory Application Engineering assistance **suggested** for operation in light shaded area and **recommended** for heavy shaded area. **Capacitor type motor required.** Table shows approximate Head-Flow for new pump in U.S. gallons per minute. (Metric equivalents shown in parentheses)

DIMENSIONAL DRAWING INCHES (MILLIMETRES)

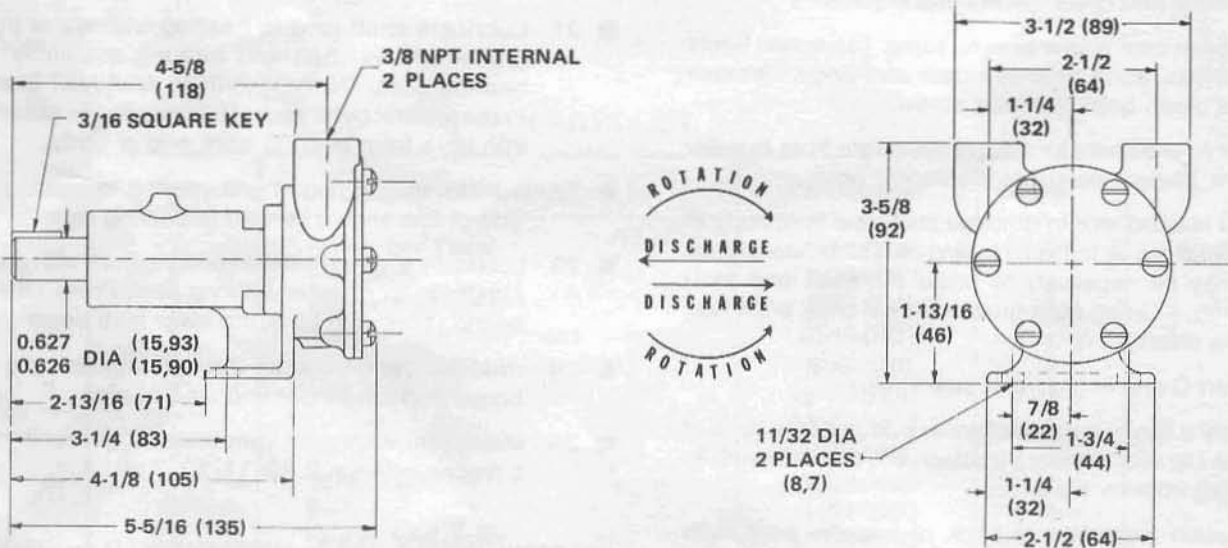

THE PRODUCT DESCRIBED HEREIN IS SUBJECT TO THE JABSCO ONE YEAR LIMITED WARRANTY, WHICH IS AVAILABLE FOR YOUR INSPECTION UPON REQUEST.

ITT Jabsco

ITT Fluid Technology Corporation
1485 Dale Way, P.O. Box 2158, Costa Mesa, CA 92628-2158
Tel: (714) 545-8251; Fax: (714) 957-0609
Bingley Road, Hoddesdon, Hertfordshire EN11 0BU England
Tel: 0992-467191; Tlx: 263251 G; Fax: 0992-467132